



MASON COUNTY ROAD COMMISSION

CRA 100 Permit

510 E State Street, PO Box 247, Scottville, MI 49454-0247

Ph: (231) 757-2882 Fax: (231) 757-2662

Application No. _____

Permit No. _____

Fee Info./Other: _____

Date Issued: _____



APPLICATION/PERMIT TO WORK WITHIN, OCCUPY, MAINTAIN OR TEMPORARILY CLOSE A COUNTY ROAD RIGHT-OF-WAY

APPLICANT INFORMATION

An applicant is defined as an owner of property adjacent to the right-of-way, the property owner's authorized representative; or an authorized representative of a private or public utility who applies for a permit to construct, operate, use, and/or maintain a facility within the right-of-way for the purpose outlined within the application. A contractor who makes application on behalf of a property owner or utility must provide documentation of authority to apply for a permit.

APPLICANT	Name:	CONTRACTOR	Company:
	Address:		Address:
	Phone No: Cell No:		Phone No: Cell No:
	Fax No:		Fax No:
	Email Address:		Email Address:

I the Applicant/Contractor request a permit for the following work within the right of way of a county road:

Plans and specifications Y N Proof of insurance Y N Communication Service Provider Y N

Traffic analysis Y N Traffic control plan Y N CSP license/terms & conditions Y N

LOCATION: County Road _____ Between _____ And _____

Township _____ Section ___ T ___ R ___ Side of Road _____ Property ID _____

DATE: Work to begin on _____; Work to be completed by _____

Applicant's signature: _____ Contractor's signature: _____

Date: _____ Date: _____

MASON COUNTY DRIVEWAY REQUIREMENTS CHECKLIST

CIRCLE ONE OF THE BELOW

CULVERT REQUIRED - YES NO REQ. DIA. _____ 55 MPH - 550', 45 MPH - 450', 35 MPH - 350', 25 MPH - 250' (MINIMUM DISTANCE)

SAFE SIGHT DISTANCE - YES NO

LANDING REQUIRED - YES NO ADDITIONAL REQUIREMENTS _____

DRIVEWAY FROM THE ROAD - FLAT
INCLINE DECLINE

APPROVED FOR CONSTRUCTION BY: _____ DATE _____



MASON COUNTY ROAD COMMISSION

CRA 100 Permit

510 E State Street, PO Box 247, Scottville, MI 49454-0247

Ph: (231) 757-2882 Fax: (231) 757-2662

Application No. _____

Permit No. _____

Fee Info./Other: _____

Date Issued: _____

PERMIT

The term "Permit Holder" in the rules and regulations set forth on the reverse side hereof, refers to the applicant and the contractor, where applicable. By performing work under this permit, the Permit Holder acknowledges and agrees that this permit is subject to all the rules, regulations, terms and conditions set forth herein, including on the reverse side hereof. Failure to comply with any of said rules, regulations, terms and conditions shall render this permit NULL AND VOID.

REQUIREMENTS	FEE TYPE	AMOUNT	RECEIPT NO	DATE	Work Order No.: _____
	Application Fee				Letter of Credit \$ _____ <input type="checkbox"/> Y <input type="checkbox"/> N
	Permit Fee				Surety Bond \$ _____ <input type="checkbox"/> Y <input type="checkbox"/> N
	Inspection Fee				Retainer Letter <input type="checkbox"/> Y <input type="checkbox"/> N
	Bond				Approved Plans on File <input type="checkbox"/> Y <input type="checkbox"/> N
	Deposit				Certificate of Insurance <input type="checkbox"/> Y <input type="checkbox"/> N
	Other				Attachments/Supplemental Specifications <input type="checkbox"/> Y <input type="checkbox"/> N
	To Be Billed				

OTHER REQUIREMENTS:

PERMIT FOR CONSTRUCTION

Recommended for Issuance By:

Approved By: _____

Title: _____

Date: _____

Title: _____

Date: _____

Revised 2/22/2023

MCRC Approved 2/22/2023

FINAL ACCEPTANCE BY MASON COUNTY ROAD COMMISSION

2nd Inspection By: _____

Approved By: _____

Attach Pictures of Driveway

Title: _____ Date: _____

Title: _____ Date: _____

Additional Comments: _____

RULES AND REGULATIONS

1. **Specifications.** All proposed work contained in this permit must be performed in accordance with the application, plans, specifications, maps and statements filed with the County Road Commission ("Road Commission"), and must comply with any modifications requested by the Road Commission and must comply with the Road Commission's current procedures and regulations on file at its offices and the current MDOT Standard Specifications for Construction, if applicable.
2. **Fees and Costs.** The Permit Holder shall be responsible for all costs incurred by the Road Commission relating to review of this application and shall deposit estimated fees and costs as determined by the Road Commission, at the time the permit is issued. Prior to permit issuance a deposit of the estimated fees and costs as determined by the Road Commission, will be require at the time the permit is issued.
3. **Bond.** The Permit Holder shall provide a cash deposit, irrevocable letter of credit or bond in a form and amount acceptable to the Road Commission at the time permit is issued.
4. **Insurance.** Without limiting the Permit Holder's indemnification of the Road Commission, the Permit Holder shall furnish (1) proof of general liability insurance providing bodily injury, property damage and personal injury liability coverage for all operations of Permit Holder in amounts not less than \$1,000,000 for each occurrence and in the aggregate, and (2) proof of personal (or commercial if the Permit Holder is operating a vehicle for business-related purposes) automobile liability insurance covering all owned, non-owned and hired automobiles and other vehicles used by Permit Holder in an amount not less than \$1,000,000 for property damage per occurrence, and not less than \$500,000 for bodily injury per person, per occurrence. If the policy providing general liability insurance is on a "claims made" form, the Permit Holder is required to maintain such coverage for a minimum of three years following completion or attempted completion of the performance of the work identified in the Permit. Except as provided above for a "claims made" form, all required insurance under Paragraphs 4 and 4.1 must remain in effect for the full term of the Permit and for at least 30 days following the expiration of the Permit, covering both ongoing and completed work performed under the Permit, and shall only be cancelled upon 30 days advance written notice to the Road Commission, by certified mail, first-class, return receipt requested. This permit is automatically invalid if any required insurance expires during the authorized period of work described herein. The need for additional types of insurance or expanded coverage limits will be evaluated on a case-by-case basis, and may be required at the Road Commission's sole discretion.
 - 4.1 **Additional Insured.** The Road Commission may require that the Permit Holder's general liability insurance policy contain an endorsement specifically identifying the Road Commission, including its commissioners, officers, agents, volunteers and employees, as an additional insured. Subject to the remaining requirements of this paragraph, the additional insured obligation may be satisfied by an endorsement providing automatic additional insured status whenever it is required in a contract or agreement executed by the Permit Holder. In all cases, the additional insured endorsement must specify that its coverage is primary and extends to the full limits of the policy. The additional insured endorsement must provide coverage for all claims or liability that are caused by, related to, or arise from the acts or omissions of the named insured or those acting on its behalf, but the provision may exclude any independent acts or omissions solely attributable to the Road Commission.
5. **Indemnification.** In addition to any liability or obligation of the Permit Holder that may otherwise exist, Permit Holder shall, to the fullest extent permitted by law, indemnify and hold harmless the Road Commission and its commissioners, officers, agents, volunteers and employees from and against any and all claims, allegations, actions, proceedings, liabilities, judgments, losses, costs, expenses (including attorney's fees), and damages arising out of (1) the negligent performance or attempted performance of the work described in the permit, or (2) the violation of the terms and conditions of the permit by the Permit Holder, its officers, agents, or employees, or (3) work performed or attempted to be performed by the Permit Holder that is not authorized by this permit, or (4) the continued existence of the operation or facility which is the subject of this permit.
6. **Miss Dig.** The Permit Holder must comply with the requirements of Act 53 of Public Acts of 1974, as amended. CALL MISS DIG AT (800) 482-7171 or www.missdig.org AT LEAST THREE (3) FULL WORKING DAYS, BUT NOT MORE THAN FOURTEEN (14) CALENDAR DAYS, BEFORE YOU START WORK. The Permit Holder assumes all responsibility for damage to or interruption of underground utilities.
7. **Notification of Start and Completion of Work.** The Permit Holder must notify the Road Commission at least 48 hours before starting work, when work is completed, and additionally as directed by the Road Commission.
8. **Time Restrictions.** All work shall be performed Mondays through Fridays between 8:00 a.m. and 5:00 p.m. unless written approval is obtained from the Road Commission, and work shall be performed only during the period set forth in this permit. Perform no work except emergency work, unless authorized by the Road Commission on Saturdays, Sundays, or from 3:00 p.m. on the day proceeding until the normal starting time the day after the following holidays: New Year's Day, Memorial Day, Independence Day, Labor Day, Thanksgiving Day and Christmas Day.
9. **Safety.** The Permit Holder shall furnish, install and maintain all necessary traffic controls and protection during Permit Holder's operations in accordance with the current *Michigan Manual of Uniform Traffic Control Devices, Part 6* and any supplemental specifications set forth herein.
10. **Restoration and Repair of Road.** The construction, operation and maintenance of the activity covered by this permit shall be performed by the Permit Holder without cost to the Road Commission unless specified herein. The Permit Holder shall also be responsible for the cost of restoration and repair of the right-of-way determined by the Road Commission to be damaged as a result of the activity which is the subject of this permit. Restoration shall meet or exceed conditions when work is commenced and be in accordance with specifications. The Permit Holder shall be responsible for costs incurred by the Road Commission for emergency repairs performed by or on behalf of the Road Commission for the safety of the motoring public. Said repairs shall be performed with or without notice to the Permit Holder if immediate action is required. This determination shall be in the sole and reasonable opinion of the Road Commission.
11. **Limitation of Permit.** Issuance of this permit does not relieve Permit Holder from meeting any and all requirements of law, or of other public bodies or agencies. The Permit Holder shall be responsible for securing and shall secure any other permits or permission necessary or required by law from cities, villages, townships, corporations, property owners, or individuals for the activities hereby permitted. Any work not described by the application, including the time and place thereof, is strictly prohibited in the absence of the application for and issuance of an additional permit or amendment to this permit.
12. **Revocation of Permit.** This permit may be suspended or revoked at will, and at the Road Commission's request, the Permit Holder shall surrender this permit or alter, relocate or remove its facilities. The Permit Holder acquires no rights in the right-of-way by virtue of this permit and expressly waives any right to claim damages or compensation in the event that this permit is revoked.
13. **Assignability.** This permit is not assignable and not transferable unless specifically agreed to by the Road Commission.
14. **Authority.** The statutory authority of the Road Commission to require compliance with permit requirements is predicated upon its jurisdictional authority and is set forth in various statutes including, without limitation and in no particular order, MCL §247.321 et seq; MCL §224.19b; MCL §560.101 et seq; and MCL §247.171 et seq.

DRIVEWAYS IN CUT SECTION

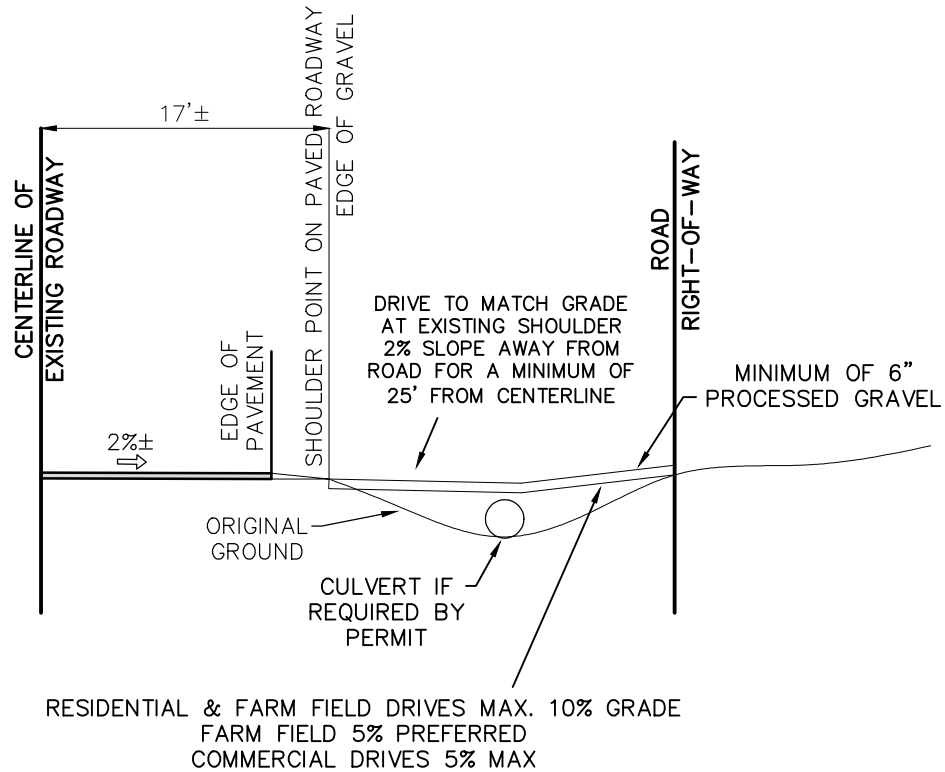

DRIVEWAYS IN FILL SECTION

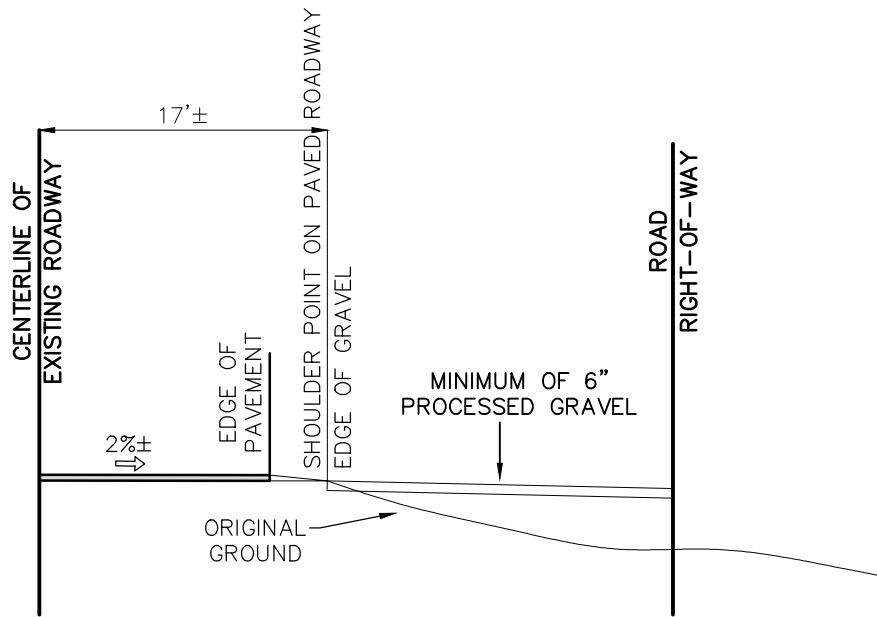

RESIDENTIAL & FARM FIELD DRIVES MAX. 10% GRADE
 FARM FIELD 5% PREFERRED
 COMMERCIAL DRIVES 5% MAX

* 15' LANDING AREA
 AT 2%± AT ROADWAY
 MAY BE REQUIRED

RESIDENTIAL DRIVEWAYS

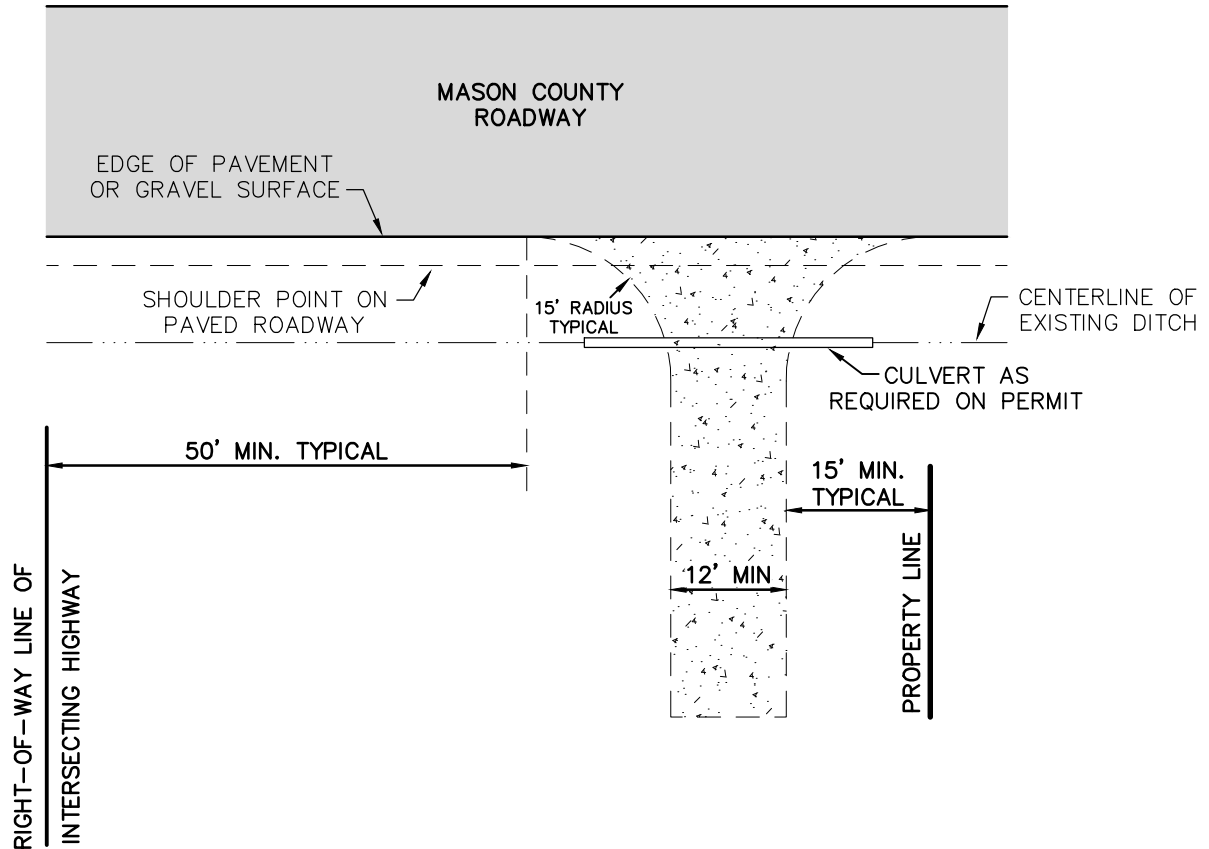

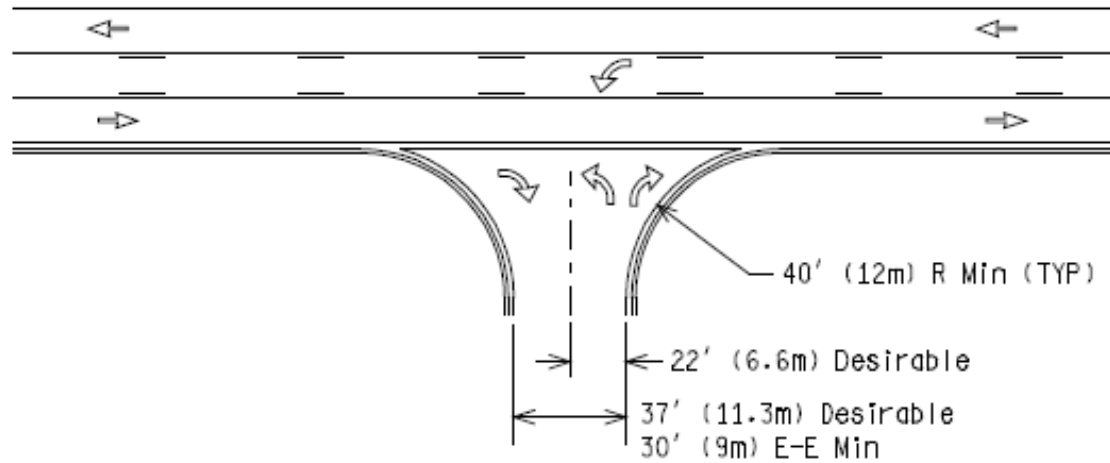

(For Three Lanes, Width Should Be
39' (11.7m) Min)

TWO-WAY DRIVEWAYS ON HIGHWAYS WITH CURB

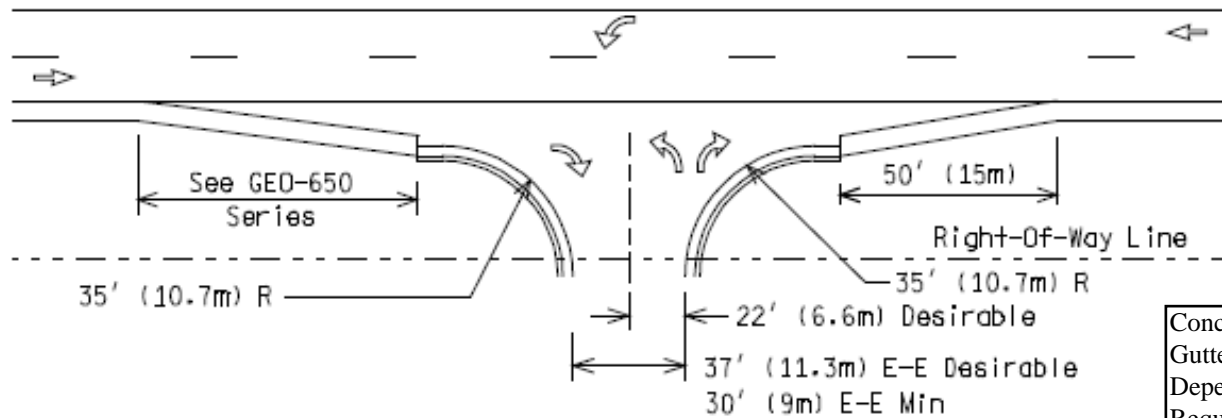

Concrete B2 Curb &
Gutter may be omitted -
Depending on Township
Requirements & MCRC

TWO-WAY DRIVEWAYS ON HIGHWAYS WITHOUT CURB